

MB-HDS212

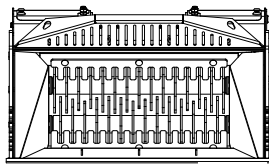

1220 mm

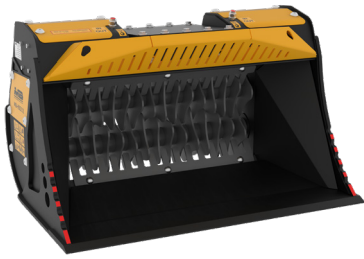
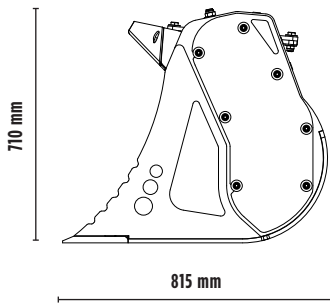

SPECIFICATIONS

	Recommended excavator	ton	5 - 10
	Recommended backhoe loader/loader**	ton	8 - 9*
	Recommended skid steer loader**	ton	3 - 4
	Weight	ton	0,48
	Load capacity	m ³	0,15
	Pressure	bar	200 - 250
	Oil flow rate***	l/min	75 - 100

* Rear

** Please verify machine's Rated Operating Capacity.

*** The minimum hydraulic flow rate value must be alongside the required operating pressure

SHAFT KIT

KIT	ADJUSTMENT*	APPLICATION
RQ8/RQ20/RQ50 Sifting kit	8/20/50 mm	Sifting damp/dry soil Soil aeration
RM Mixer kit	-	Soil aeration Compost aeration Charcoal reduction Glass reduction Drywall reduction
RE8/RE16 Fine Sifting kit	8/16 mm	Sifting damp/dry soil
RC Compost kit	36,5 mm	Shredding foliage and small branches Composting

* Shafts in closed position.

ACCESSORIES

RQ8/RQ20/RQ50 Sifting kit	RM Mixer kit
RE8/RE16 Fine Sifting kit	RC Compost kit
Shaft holder	24 month warranty

APPLICATION AREAS



ROAD WORKS



TUNNELS



ENCLOSED SPACES



PIPELINES



RECYCLING AGGREGATES



EXCAVATION



URBAN CONSTRUCTION SITES



FOUNDRIES



MAINTAINING LANDSCAPE AND AGRICULTURAL AREAS