

## PATCH PLANER

# EX 30 HD

Patch planer for milling asphalt and concrete with accurate depth control

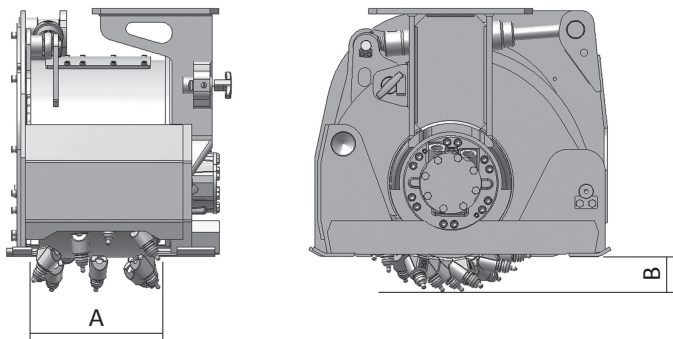

## TECHNICAL DATA | EX 30 HD

Recommended excavator weight	t	5–10
Rated power	kW	30
Cutting width, standard (A)	mm	300
Cutting depth, adjustable (B)	mm	0–120
Recommended rotation speed	rpm	80–125
Recommended oil flow at 100 bar	l/min	60–95
Minimum oil flow	l/min	60
Maximum oil flow	l/min	110
Maximum hydraulic pressure	bar	380
Torque at 350 bar	Nm	4.100
Cutting force at 350 bar	kN	16
Operating weight	kg	400
Number of picks	Pcs	35
Standard pick <sup>1)</sup>	Type	ER 16/48/32/20 H

## EXR 30 HD | WITH ROTATION

Recommended excavator weight	t	6–10
Operating weight	kg	585

<sup>1)</sup> Cutter drums can be supplied with picks for special applications as required.