

VSP(VPR) Series Secondary Pulverizers

Designed for secondary processing to remove rebar and size concrete.
 Rotation model, 360 degree hydraulic, increases productivity.
 Large model selection is available for most carriers.

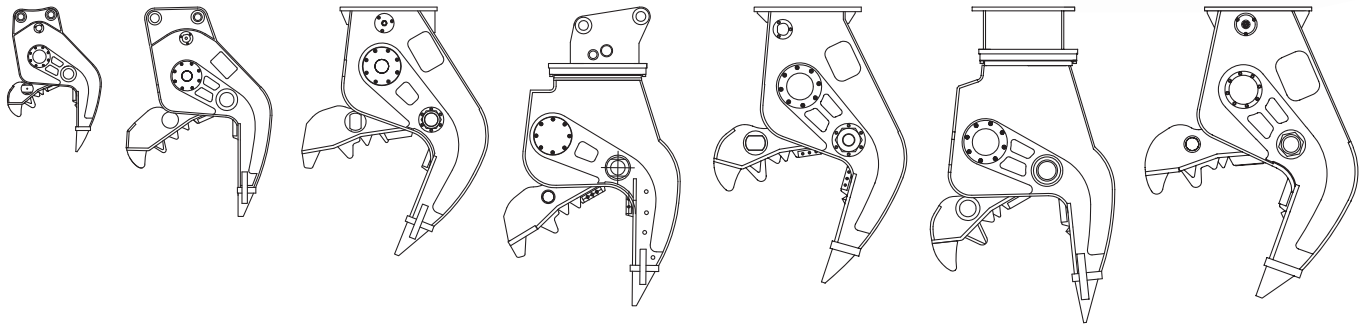

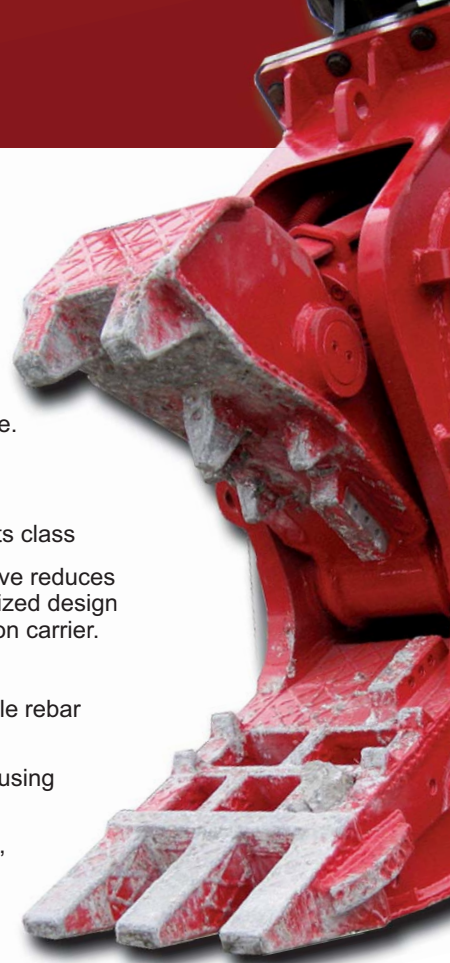
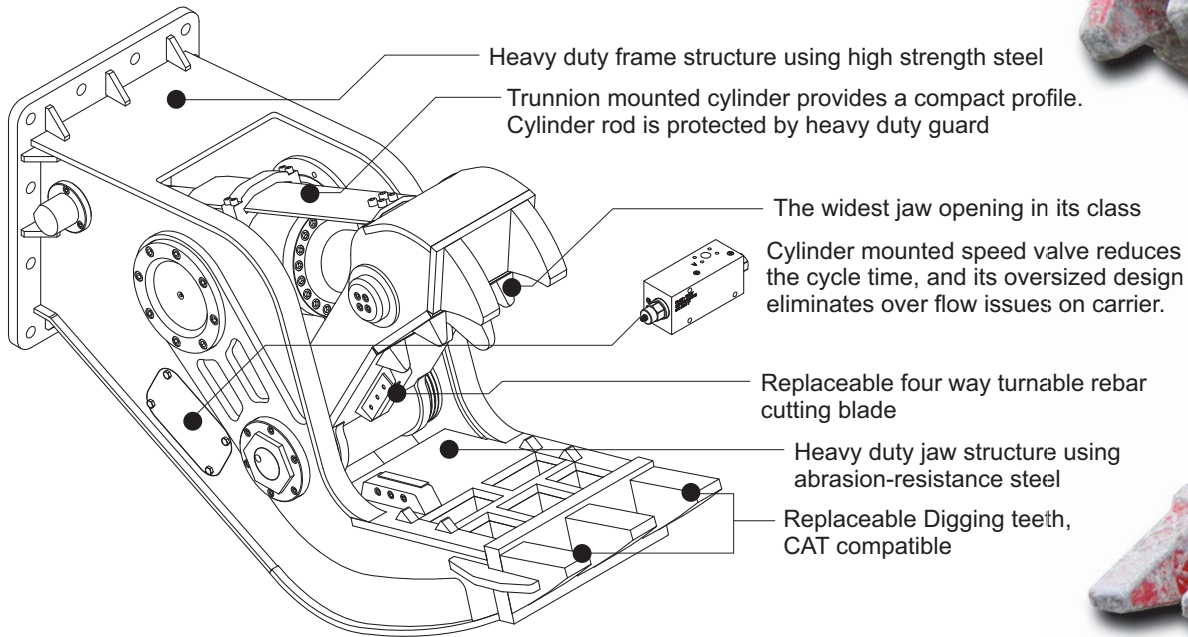
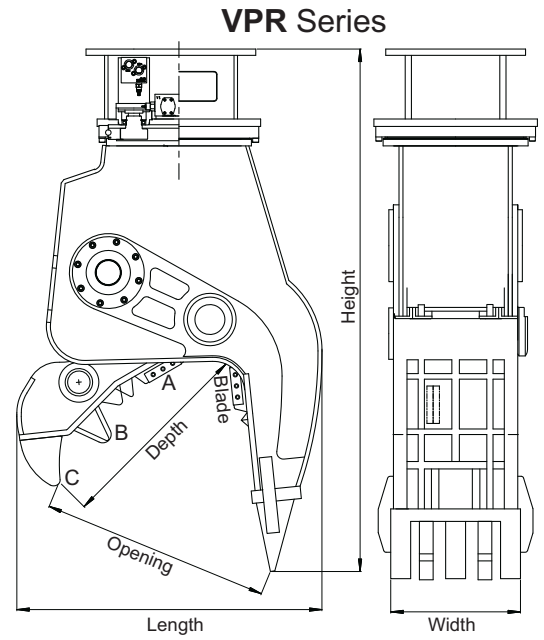
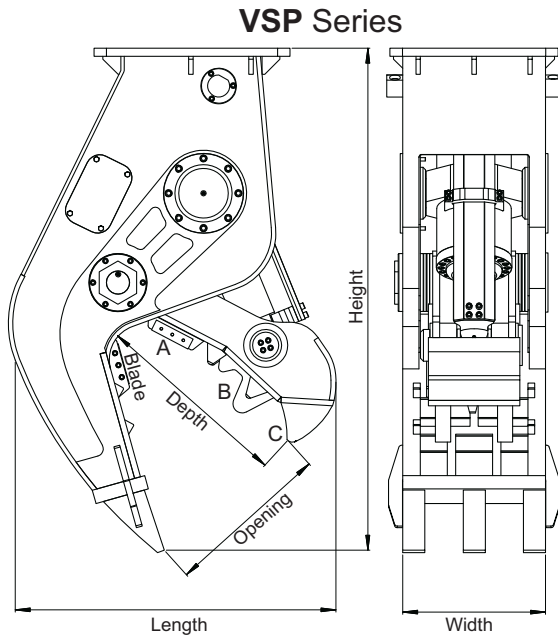

Model	Unit	VSP 052	VSP 122	VSP 152	VPR 152	VSP 182	VPR 182	VSP 202	VSP 352	Unit	VSP 052	VSP 122	VSP 152	VPR 152	VSP 182	VPR 182	VSP 202	VSP 352									
Carrier Weight	M/T	2~5	7~12	10~20	12~20	17~25	20~30	23~40	35~45	M/T	2~5	7~12	10~20	12~20	17~25	20~30	23~40	35~45									
Operating Weight	kg	250	570	950	1,150	1,500	1,850	1,950	3,600	lb	550	1,270	2,090	2,530	3,300	4,070	4,290	7,920									
DIM	Height	1,020								mm	1,380								inch	65							
	Length	620									960									48							
	Width	260									355									17							
Jaw Opening	mm	440								inch	700								31								
Jaw Depth		395									680								32								
Blade Length		75									102								5.5								
Cutting Force [A]	M/T (Metric Ton)	37								lb (X1000)	87								359								
Crushing Force		[B] Mid	17								74								200								
		[C] Tip	11								46								132								
Rated Pressure	bar	250				320					psi	3,600				4,600											
Rated Oil Flow	lpm	45	80	160			280		360	gpm	12	21	42		74		95										
Hyd. Rotation	Pressure	bar	-	-	-	210	-	210	-	psi	-	-	-	3,000	-	3,000	-	-									
	Oil Flow	lpm	-	-	-	28~32	-	40~45	-	gpm	-	-	-	7~8	-	10~14	-	-									
	Speed	RPM	-	-	-	10~15	-	10~15	-	RPM	-	-	-	10~15	-	-	-	-									
Cycle time	Open	sec	1.3	2.0	2.1	1.9	2.9	2.9	2.2	3.0	sec	1.3	2.0	2.1	1.9	2.9	2.9	2.2	3.0								
	Close		1.3	2.6	1.9	1.8	3.0	3.0	1.9	3.1		1.3	2.6	1.9	1.8	3.0	3.0	1.9	3.1								

Specifications subject to change without notice.

- VPR model comes come with continuous 360degreee hydraulic rotation.
- Height : Flat Top Mounting
- Cycle Time : Measured at rated flow under no load.