

MOUNTING BRACKET

- Easy installation of clamps and tubes.
- Anti-corrosion coated.



604-888-9020
sales@vanedequipment.com

21-3485
Angle Bulkhead Bracket

Welding Hole (X2)

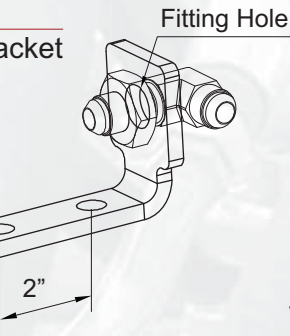

21-3459
L Clamp Bracket

WCA100 or WCA125
: 1 ~ 1.25" Alumium Clamp

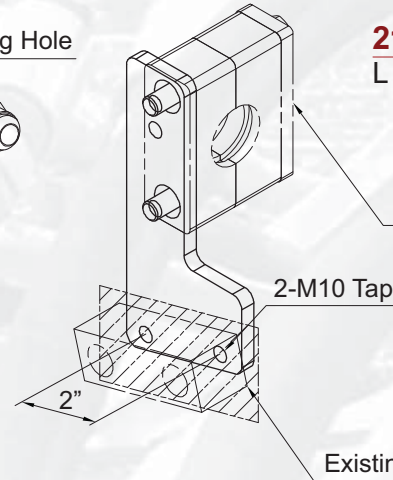

21-3508
Angle Clamp Bracket

WCA100 or WCA125
: 1 ~ 1.25" Alumium Clamp

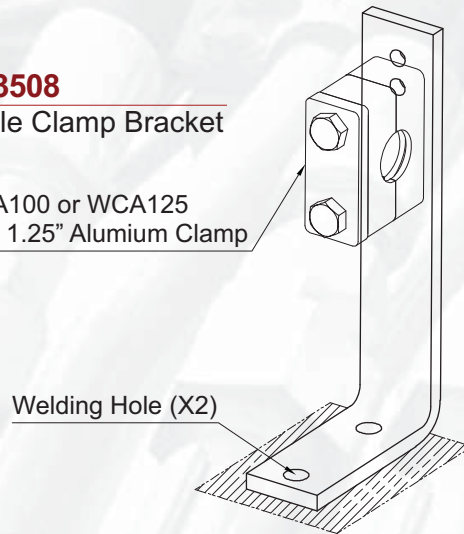

21-3511
L Clamp Bracket, Double

WCA100 or WCA125
: 1 ~ 1.25" Alumium Clamp

