

# Tiltrotator EC219

## For 30,900-41,900 lbs excavators (14-19 metric ton)

A compact, powerful tiltrotator with low weight and height for excavators up to 19 metric tons. If EC219 is selected with engcon's standard Quick Coupler S60 and the DC2 proportional control system, EC-Oil automatic Quick Coupler system is offered as a free standard.\*\* This means that the tiltrotator and hydraulic tools can be connected & disconnected without the operator needing to leave the cab.

Supplied complete with hoses, quick couplings and electrical equipment for one machine.

### Features:

- » The EC-Oil automatic Quick Coupler system connects the tiltrotator & hydraulic tools without the operator needing to leave the cab\*\*
- » Q-Safe quick coupler for maximum safety
- » Comes ready for detachable grabber GRD (S60)
- » Comes ready for rotating brush SWD (S60)
- » Comes ready for the QSC locking system to avoid improperly connected or dropped buckets
- » Comes ready for rotation sensor (ePS) for connection to the excavator guidance system
- » Central lubrication (a single grease point for the entire tiltrotator; can also be connected to the excavator's central lubrication system)
- » Load-holding valves on tilt cylinders for maximum safety
- » Hardened piston rods
- » Up to ± 45-degree tilt angle for best access
- » Rotation ∞

**Quick coupler:** S60 comes standard. For other purposes, we can supply most types of couplers available on the market.

**Control system:** DC2 comes standard. This proportional control system provides outstanding variable control with remote support capability, track/wheel steering, and boom slew. We also offer custom control systems.

**Electrical system:** Can be adapted to 12V or 24V electrical systems.

**Accessories:** GRD detachable grabber cassette\*, SWD rotating brush\*.

\* Read more about GRD and SWD at [engcon.com](http://engcon.com)

\*\* Read more about the terms and conditions regarding EC-Oil automatic Quick Coupler system as a free standard at [www.engcon.com](http://www.engcon.com)



### Specifications

Model	EC219
Width A (inches)*:	15.6
Width B (inches)*:	12.4
Width C (inches)*:	12.2
Total length D (inches)*:	29
Construction height E (inches)*:	from 18.9
Weight (lbs)*:	983.4
Tilt range:	2x45°
Rec. hydraulic flow DC2 & SS10 (gpm):	31.7
Rec. hydraulic flow SS9 tilt/rotation (gpm):	17.2/18.5
Max hydraulic pressure (psi):	3,191
Standard mountings:	S60
Max bucket width rec. by engcon (inches):	66.9
Max torque (lbf):	137,187
Base machine weight min/max (lbs):	30,900–41,900

\*Standard attachment

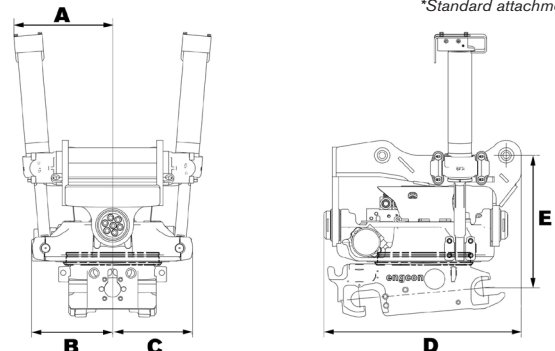

**CHANGE THE WORLD OF DIGGING**