

Specifications

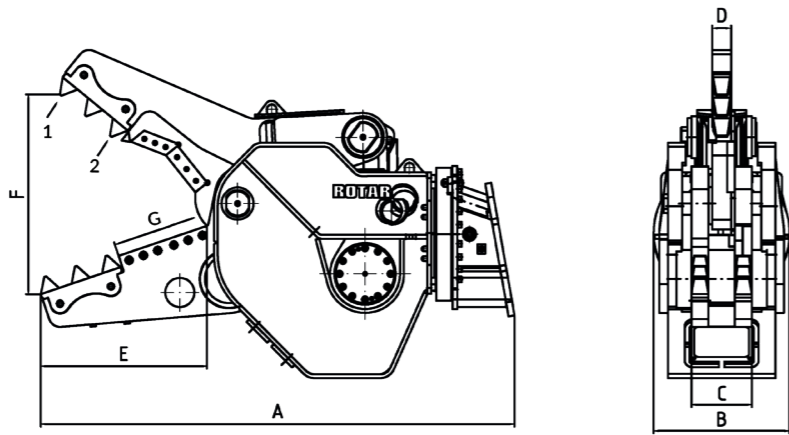

Ingenious, reliable, service-friendly and maximal productivity.
That is the power of Rotar!

Type RDC	20 S	25 S	32 S	42 S
Information				
Machine class (t)	15 - 25	24 - 35	30 - 45	45 - 70
Weight (kg)*	1950	2670	3050	4100
Cyclus open/close (s.)	1,9 - 1,2	2,2 - 2,4	2,5 - 2,8	2,6 - 2,8
Closing force at position 1 (t)	63	68	85	102
Closing force at tip of jaw 2 (t)	80	100	125	140
Dimensions				
Dimension A (mm)	2100	2259	2508	2730
Dimension B (mm)	760	760	760	880
Dimension C (mm)	280	320	320	340
Dimension D (mm)	90	100	100	100
Dimension E (mm))	650	775	880	1020
Dimension F (mm)	700	900	955	1230
Dimension G (mm)	400	400	500	600
Attachment				
Rotar Hole-pattern	140 - 150	140 - 150	140 - 150	150
Hydraulic				
Max. operating pressure cylinder (bar)	350	350	350	350
Oil volume cylinder (L/min)	150 - 250	150 - 250	250 - 300	250 - 350
Max. operating pressure motor (bar)	170	170	170	170
Oil volume motor (L/min)	40 - 60	40 - 60	40 - 60	40 - 60

* Weight exclusive adapterplate with bracket.

** Figures given for cycle times and cutting forces are indications only. External factors such as excavator setting, hydraulic infrastructure, quickcouplers and fittings may influence performance.

*** Technical specifications are subject to change without prior notice.



RDC-Series

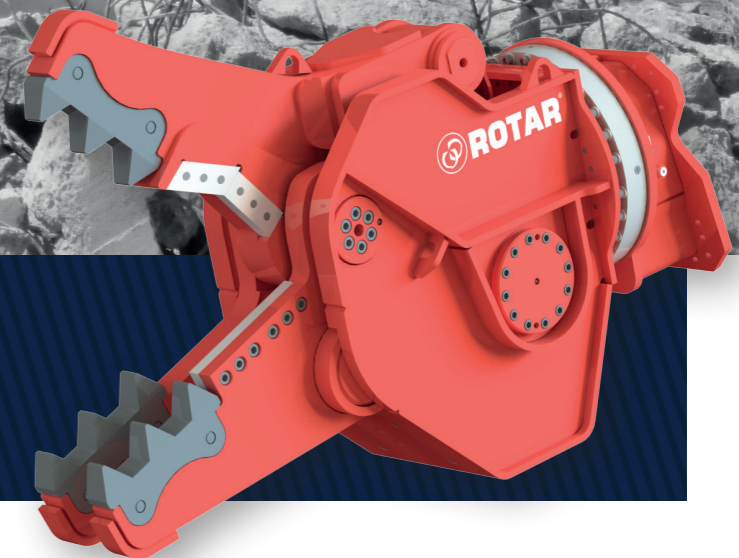

Rotar International BV

Address Sisalstraat 85, 8281 JK Genemuiden (NL)

Tel. +31(0) 38 385 54 71

Fax +31(0) 38 385 54 02

E-mail info@rotar.com

Website www.rotar.com



Rotar Demolition Combi Shear

Incredible crushing power combined with tremendous cutting power makes the Rotar Demolition Combi Shear the perfect machine for primary demolitions. The RDC will work its way through any concrete construction and steel beams. The new, stable pivot point design, guarantees successful cutting in the long term.

Replaceable teeth and cutting knives

The RDC Series is fitted with replaceable casting teeth and cutting knives. The design of the teeth guarantees powerful penetration. It is an impressive sight to see the teeth and knives cutting through the extremely strong concrete and steel constructions. The RDC Series' body is assembled from first-class and long-lasting materials, making it extremely strong.



Upper head and slewing ring

The RDC Series is fitted with a strong rotating upper head and a heavy-duty, double-rowed slewing ring. The hydraulic motors in the headpiece generate a high torque, allowing the RDC Series to be moved in every possible position.



Specially developed speed valve

The speed valve developed by Rotar allows the jaws to close quickly and automatically switch from speed to power mode as soon as the job requires more cutting power.



Trunnion hydraulic cylinder

The construction of the hydraulic cylinder ensures optimum efficiency of the cutting power and a compact design with a favorable center of gravity. The large diameter of the hoses, bores and pipes reduces the back pressure in the hydraulic system and contributes to the extraordinary features of this RDC.



GET THE
RED CRUSH!