

MIDSIZE DEMOLITION SORTING GRAB HSG

FOR 10-20 TON CARRIER

Silent Demolition and Sorting/Loading Grapple

- With 360 degree rotator, operator can align jaws without moving machine and pick material from any angle.
- With synchronized jaws, operator can pick small items and place very precisely.



604-888-9020
sales@vanedequipment.com

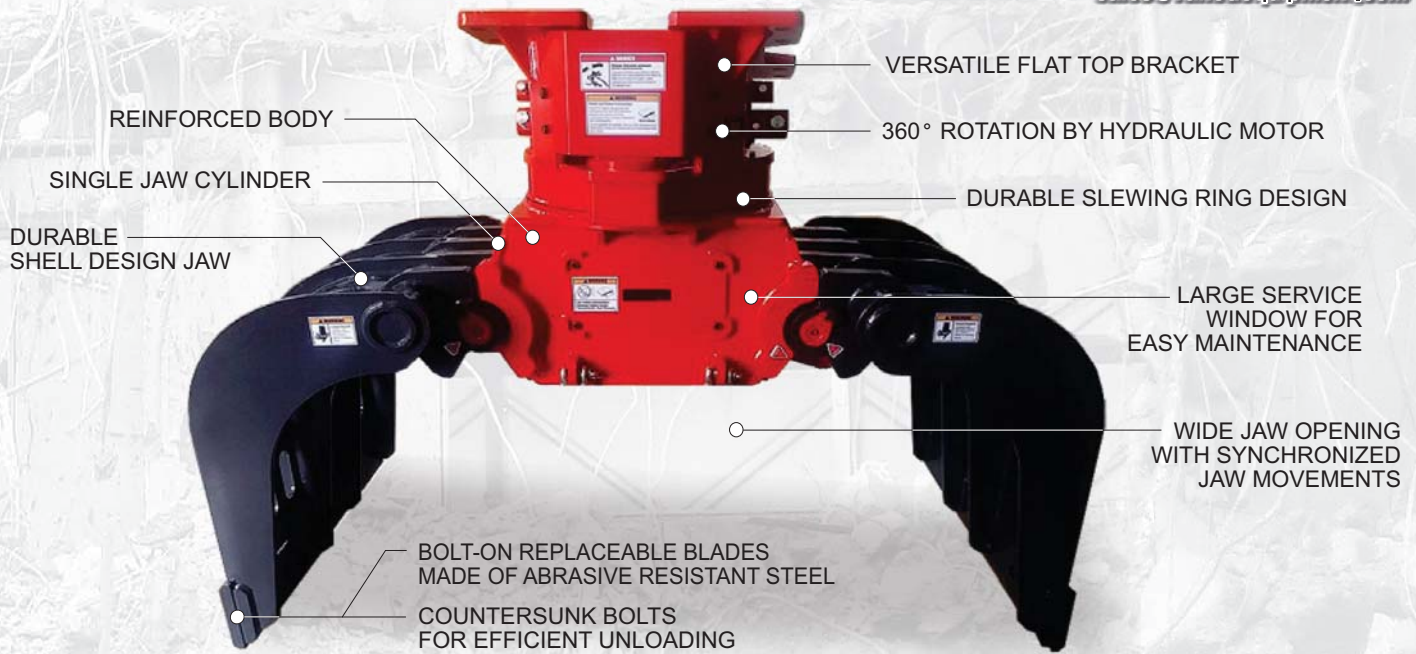

Model	Unit	HSG13R	HSG21R	
Recommended Carrier	Metric Ton	8~15	16~22	
Weight	kgs	1,040	1,580	
	lbs	2,288	3,480	
Opening	mm	1,900	2,130	
	inch	75	84	
Width	mm	900	1,000	
	inch	35	39	
Depth	mm	520	625	
	inch	20	25	
Areal Capacity	m ²	0.60	0.80	
	yd ²	0.78	1.04	
Volume Capacity	liter	540	800	
	yd ³	1.57	2.35	
Jaw	Rated Pressure	bar	350	350
		psi	5,080	5,080
	Rated Flow	lpm	80	120
		gpm	21	31
Closing Force	Metric Ton	5.2	7.0	
	lbs (x1,000)	2.36	3.18	
Rotator	Rated Pressure	bar	170	170
		psi	2,465	2,465
	Rated Flow	lpm	17	35
		gpm	4	9
Speed	RPM	12	12	

Specifications are subject to change without notice.