

LARGE SECONDARY PULVERIZERS VSP-A

FOR 20-60 TON CARRIER

Designed secondary processing to remove rebar and size concrete. Replaceable teeth reduce maintenance time and cost.

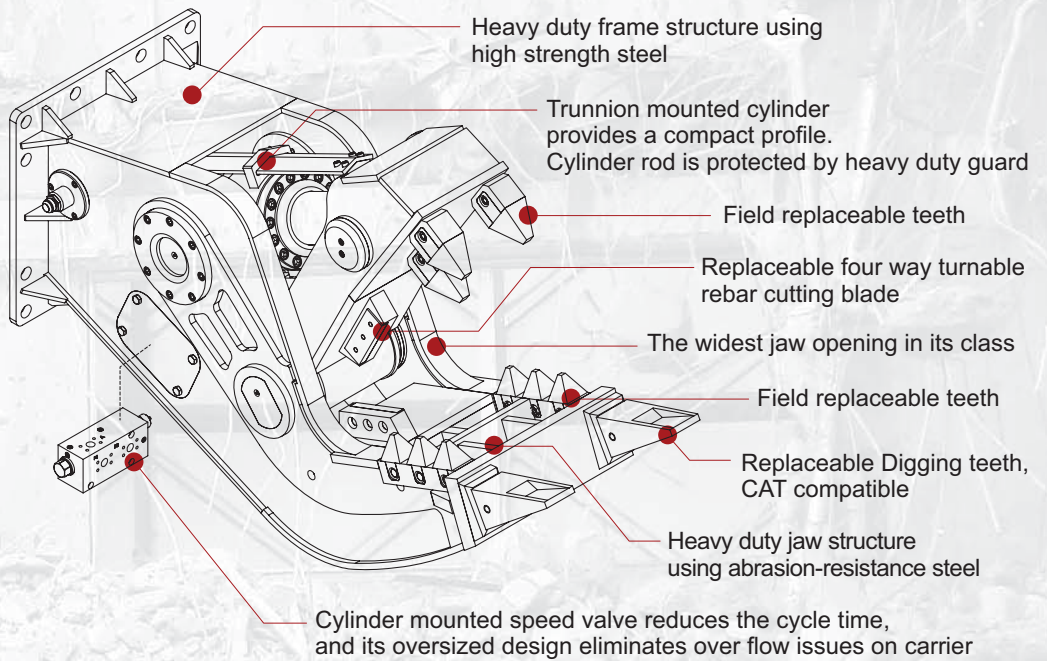

TEETH COMPARISON with NON A series

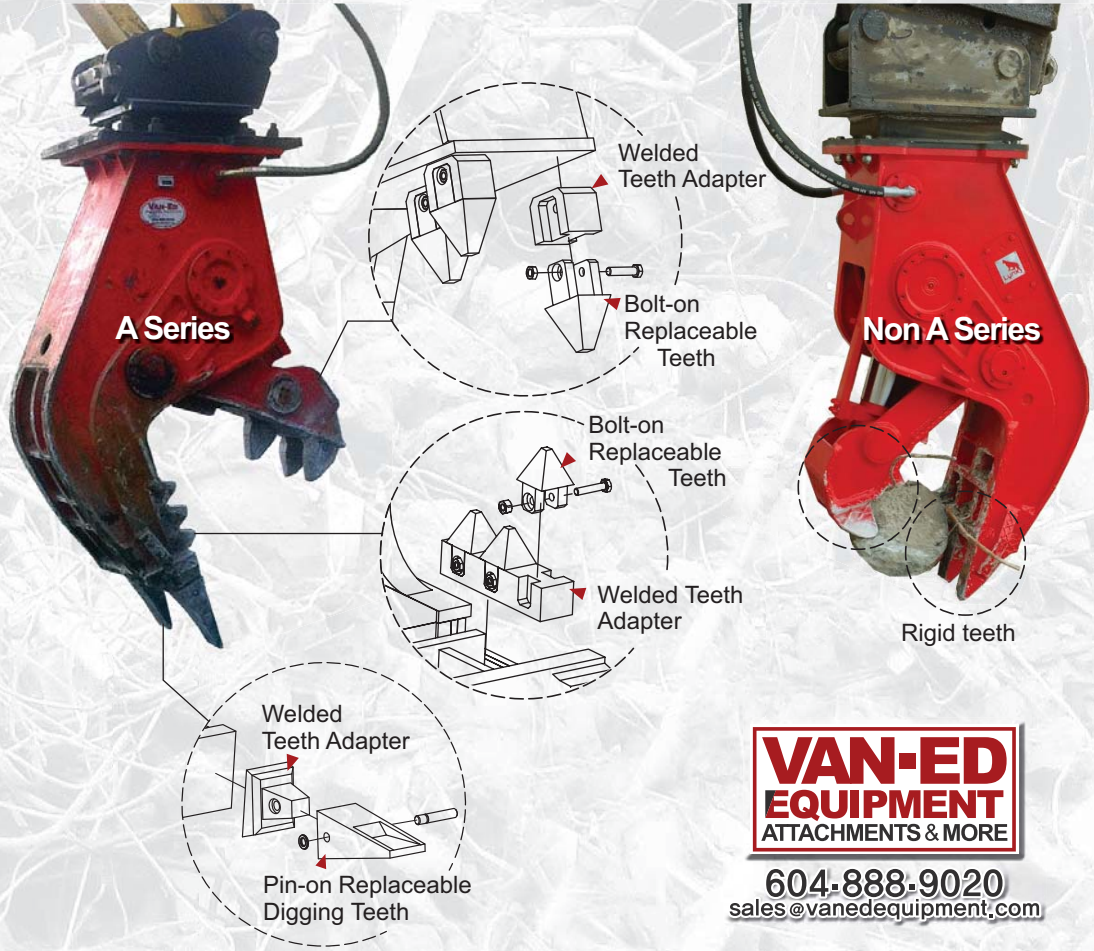

604-888-9020
sales@vanedequipment.com

LARGE SECONDARY PULVERIZERS VSP-A

FOR 20-60 TON CARRIER

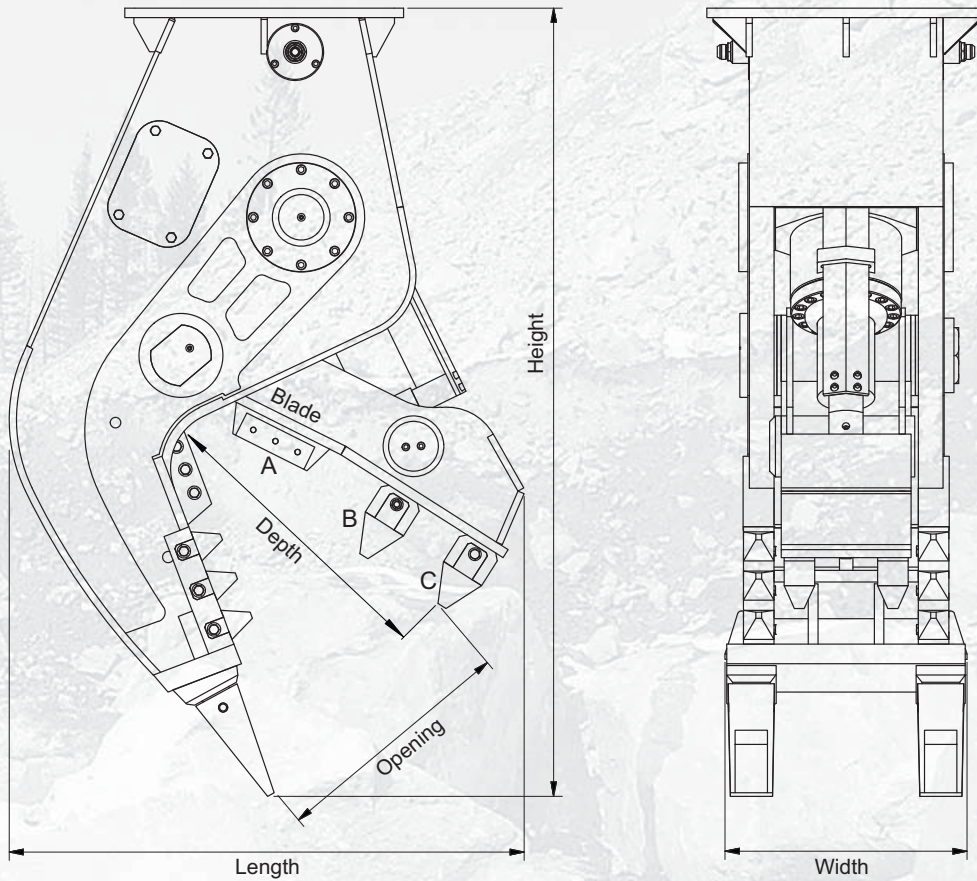

Model	Unit	VSP 202A	VSP 302A	VSP 352A	Unit	VSP 202A	VSP 302A	VSP 352A	
Carrier Weight	M/T	20~30	24~42	35~45	M/T	20~30	24~42	35~45	
Operating Weight	kg	2,040	2,450	3,600	lb	4,490	5,390	7,920	
DIM	Height	1,960	2,190	2,600	inch	77	86	102	
	Length	1,420	1,620	2,200		56	64	87	
	Width	540	600	830		21	24	33	
Jaw Opening	mm	925	1,100	1,190	inch	36	43	47	
Jaw Depth		870	990	1,100		34	39	43	
Blade Length		200	200	250		7.9	7.9	9.8	
Cutting Force [A]		202	257	306		445	565	673	
Crushing Force	[B] Mid	M/T (Metric Ton)	95	121	132	lb (X1000)	209	266	290
	[C] Tip		62	79	98		137	174	216
Rated Pressure	bar		320		psi		4,600		
Rated Oil Flow	lpm	280	320	360	gpm	74	84	95	
Cycle time	Open	sec	2.2	2.2	3.0	sec	2.2	2.2	3.0
	Close		1.9	1.9	3.1		1.9	1.9	3.1

Specifications subject to change without notice.

- Height : Flat Top Mounting
- Cycle Time : Measured at rated flow under no load.